



Primelite Manufacturing Corp

407 S Main St, Freeport, NY 11520

Phone: 516-868-4411 | Fax: 516-868-4609
 sales@primelite-mfg.com | www.primelite-mfg.com

PART # #ESW	LAMP N/A	VOLTAGE N/A	COLOR Powder Coated Paint
JOB NAME			TYPE Accessory

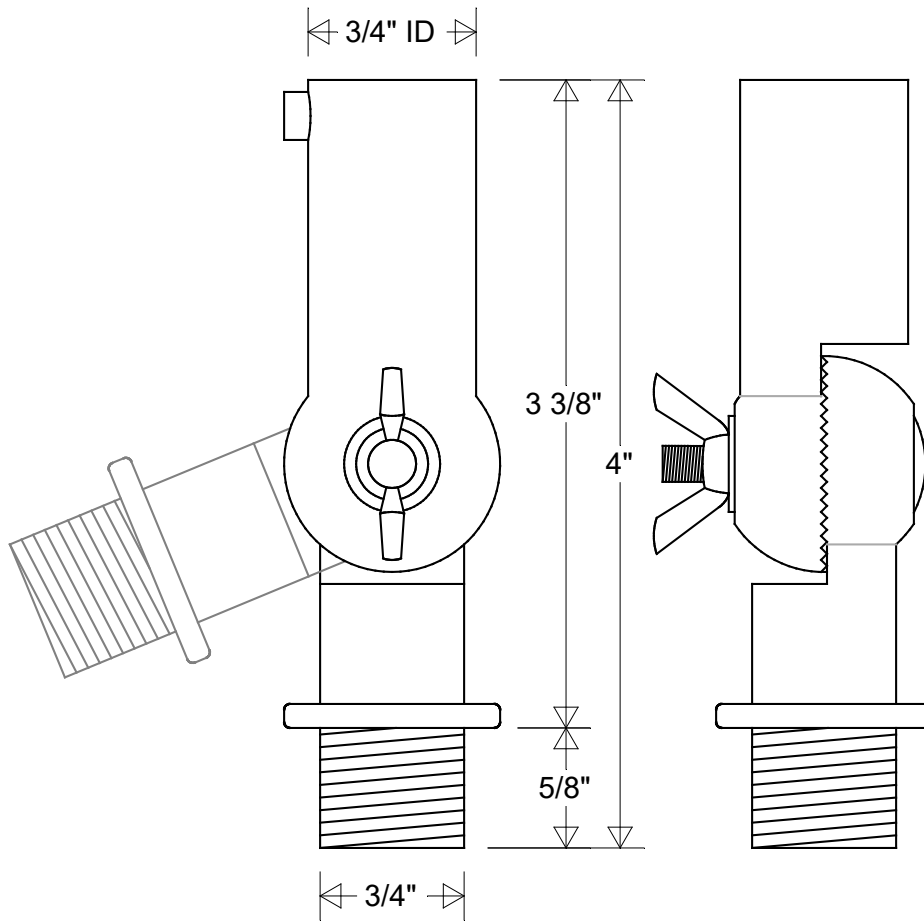

Lamp: N/A	Initials	Date	Accessory #ESW																													
	Drawn	CB						08/2022																								
	Checked			Swivel for 1/2" IPS Stems and Arms																												
	ENG Appr.																															
Construction: Aluminum	MFR Appr.		Size	Drawing No.	Rev	<table border="1"> <thead> <tr> <th colspan="5">Revisions</th> </tr> <tr> <th>Zone</th> <th>Rev</th> <th>Description</th> <th>Date</th> <th>Appr</th> </tr> </thead> <tbody> <tr> <td> </td> <td> </td> <td> </td> <td> </td> <td> </td> <td> </td> </tr> <tr> <td> </td> <td> </td> <td> </td> <td> </td> <td> </td> <td> </td> </tr> </tbody> </table>					Revisions					Zone	Rev	Description	Date	Appr												
	Revisions																															
Zone	Rev	Description	Date	Appr																												
QA			A	0001	A																											
Unless Otherwise Specified: Dimensions in Inches	Weight:		Scale	CAD File	Sheet	1 of 1																										